

otmedical®

Innovative Präzision
Made in Germany



OT-F² / OT-F³
Product Catalog

Notes

A large grid of small dots, intended for taking notes. The grid consists of 20 columns and 30 rows of dots, spaced evenly across the page.

OT-F²/OT-F³ IMPLANT SYSTEM

Table of contents

SYSTEM OVERVIEW

Page 5 - 11

OT-F ² /OT-F ³ System presentation	5
OT-F ² Implant overview	6/7
OT-F ³ Implant overview	8/9
OT-F ² /OT-F ³ Implant packing	10/11

SURGERY

Page 12 - 21

OT-F ² Surgical Tray content	12-15
OT-F ³ Surgical Tray content	16-20
OT-F ² /OT-F ³ Instruments & Accessories	21

PROSTHETICS

Page 22 - 43

OT-F ² /OT-F ³ Prosthetic overview	22
OT-F ¹ Indication overview	23
OT-F ² /OT-F ³ Impression & master cast	24-27
OT-F ² /OT-F ³ Prosthetic components	28-43



OT MEDICAL

Made in Germany

Securing quality and advancement of our products

Our products have been designed by keeping a high-grade medical treatment in mind. We stand ready and are able to maximize the treatment effectiveness and the benefit of our products based on customer needs and requirements generated through their daily surgery. The center of attention is an effective, reliable and secure treatment methodology as well as a functional and esthetic patient treatment.

We are committed to the further advancement of our products in both the medical and technical aspects. No compromise is tolerated in the security and quality.

We stand for the quality feature "Made in Germany" and rely on our highly qualified and motivated employees.

A content team is the key to success

Products based on the demands of high quality and scientific standards and satisfied customers are in focus of our daily work. In order to reach this goal, the satisfaction of our staff members is a priority.

With the competence and experience, each and every co-worker contributes decisively to the overall success.

Partnership with convinced customers

We are grateful to our customers for the overall success of our efforts. We intend to inspire with our products and services, and we would like to cooperate in a partnership.

Our work is solution-oriented and focused on quality

The results achieved as well as the effectiveness of the final product should please everyone involved. The work does not only concern the fulfilment of regulations, but encompasses a continued improvement of the processes. Problems which may occur are being analyzed, evaluated and corrected. At the same time, we are trying to improve the sustainability of our environment and to support the work security and protection of everyone's health.

The basis for the manufacturing of quality, high-grade implants and their accessories is accomplished through the fulfilling of all national and international normative requirements. Moreover, we conduct regular studies, tests and analyses as part of our international research and development activities.

Your OT medical team

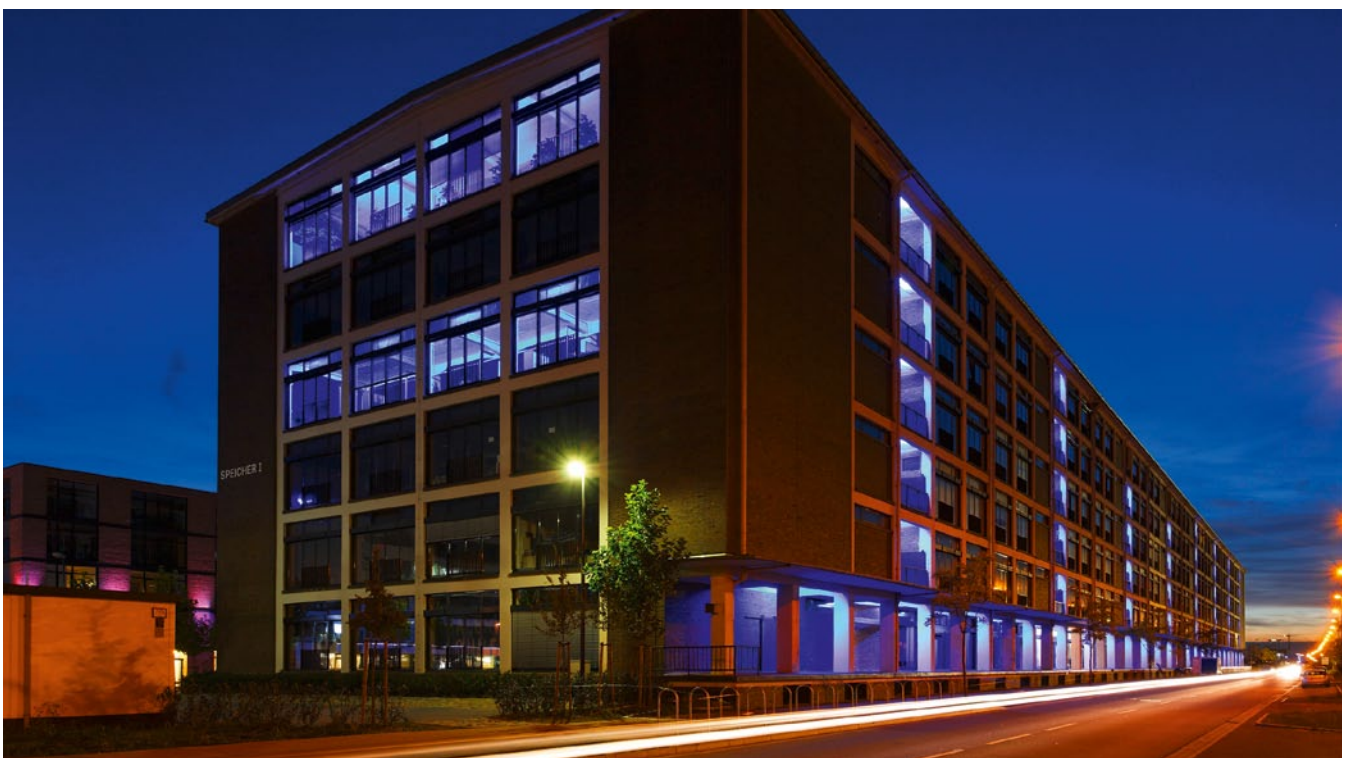

OT-F²/OT-F³ IMPLANT SYSTEM

Internal connection

OT-F² AND OT-F³

Identical „FourByFour®“ internal connection

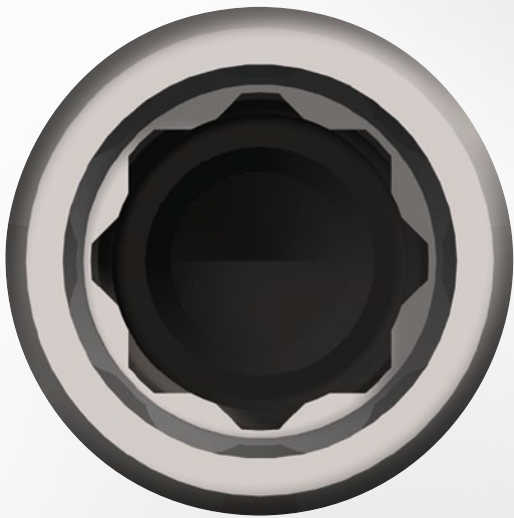

The stable internal connection leads to a simple, safe positioning of prosthetic components. Platform switching, cone-shaped entry and a highly precise rotation lock are outstanding features of this modern concept.

The compatibility of both systems OT-F² and OT-F³ regarding prosthetic components contributes to a clear arrangement and user friendliness. Thus the prosthetic line is easily understandable and less cost intensive.

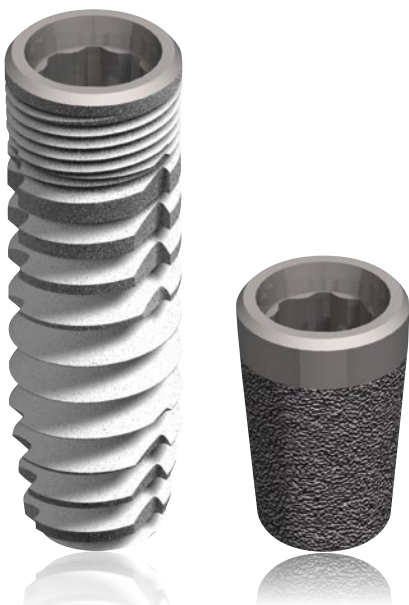
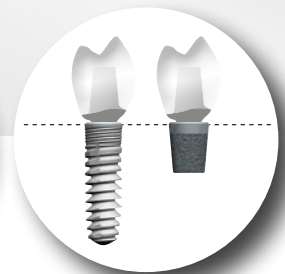
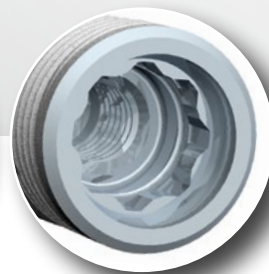

- PROSTHETIC COMPATIBILITY
with identical FourByFour® internal connection
for the OT-F² and OT-F³ implants
- PLATFORM SWITCHING
better esthetics with vigorous soft tissue
and long-term preservation of the crestal bone
- CONE-SHAPED ENTRY
for a secure and tight implant to
abutment connection
- HIGHLY PRECISE ROTATIONAL LOCK
for easy and stable positioning of the prosthetic components

OT-F² IMPLANT SYSTEM

System presentation

OT-F² BSE surface images
Copyright: Dr. Dirk Duddeck | dedeMED

OT-F² SCREW IMPLANT

A strong companion in daily implantology routine

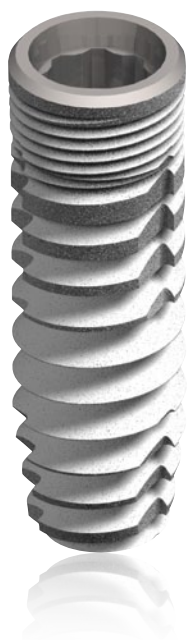
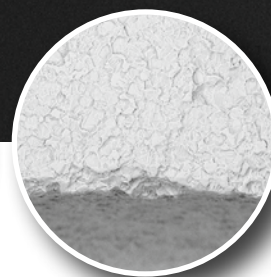
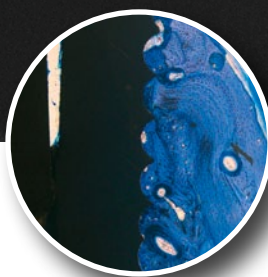
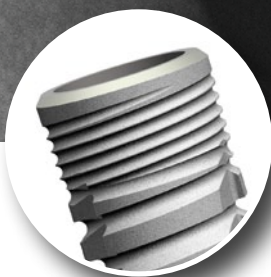

- **SELF-TAPPING MACRO THREAD**
for a reliable insertion and defined primary stability
in connection with an optimized drill design
- **CRESTAL MICRO-THREADS**
for an ideal load distribution, increased bone growth
and more vitality
- **NANOPLAST® PLUS SURFACE**
(HA-blasted and acid-treated)
helps to ensure optimal osteoconductivity
- **EASY AND TIME EFFICIENT DRILL PROCEDURE**
through the use of length congruent drills
with optional Drill Stops

OT-F² IMPLANT SYSTEM

Implant overview

OT-F² Screw Implant

Implant design

The innovative implant design of OT-F² implant represents a new interpretation of self-tapping compression threads. The specially designed cutting notches reduce the insertion torque of the implant without affecting the high primary stability.

The crestal micro threads help to ensure the preservation of cortical bone loss. The initial high BIC (Bone-Implant-Contact) allows a safe transition from primary to secondary stability and thus excellent osseo-integration.

Platform switching, conical entry and a high-precision FourBy-Four® rotational lock distinguish the implant to abutment connection.

Implant surface

The micro and macro structures of the HA-blasted and acid-treated NanoPlast® Plus surface ensures optimal osteo-conductivity and thereby enables secure bone integration. The pro-gressive and scientifically tested manufacturing processes ensure a pure surface without harmful residues.

Indications

The OT-F² implant is suitable not only for insertion in completely healed jaw bone (late implantation), but also for delayed insertion (6-8 weeks after tooth extraction), as well as at corresponding preconditions for immediate implantation (directly after tooth extraction). OT-F² implants can be used in all bone qualities of the maxilla and mandible (D1-D4).

Please note the limitations of indication for use of implants with a diameter of 3.40 in the Instructions for Use.

If you find this pictograph please note, that the product concerned is to be used only for the OT-F² implant system.



Material: Titanium grade 4

Diameter		Length	Art. No.
3.40 mm	●	8 mm	02-1342080010
3.40 mm	●	10 mm	02-1342100010
3.40 mm	●	12 mm	02-1342120010
3.40 mm	●	14 mm	02-1342140010
3.40 mm	●	16 mm	02-1342160010
3.80 mm	●	8 mm	02-1382080010
3.80 mm	●	10 mm	02-1382100010
3.80 mm	●	12 mm	02-1382120010
3.80 mm	●	14 mm	02-1382140010
3.80 mm	●	16 mm	02-1382160010
4.10 mm	●	8 mm	02-1412080010
4.10 mm	●	10 mm	02-1412100010
4.10 mm	●	12 mm	02-1412120010
4.10 mm	●	14 mm	02-1412140010
4.10 mm	●	16 mm	02-1412160010
5.00 mm	●	8 mm	02-1502080010
5.00 mm	●	10 mm	02-1502100010
5.00 mm	●	12 mm	02-1502120010
5.00 mm	●	14 mm	02-1502140010

„Take care“-Patient set, pack of 10 09-700370001

Small zipper bag with important information what to do after insertion, incl. accessories for patients



Note

M1.6
M1.8

The OT-F² implants ø 3.40/3.80 have inner threads of the size M1.6, the implants ø 4.10/5.00 mm size M1.8.

OT-F³ IMPLANT SYSTEM

System presentation

OT-F³ SHORT IMPLANT

Smooth alternative for reliable results

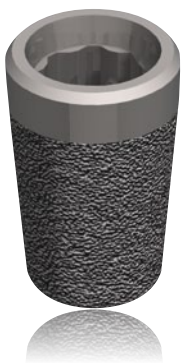
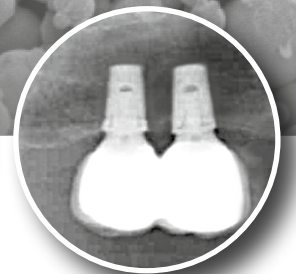
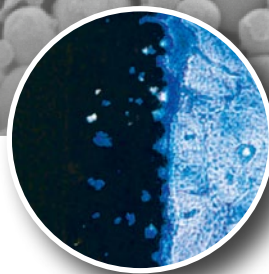
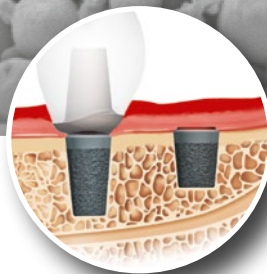
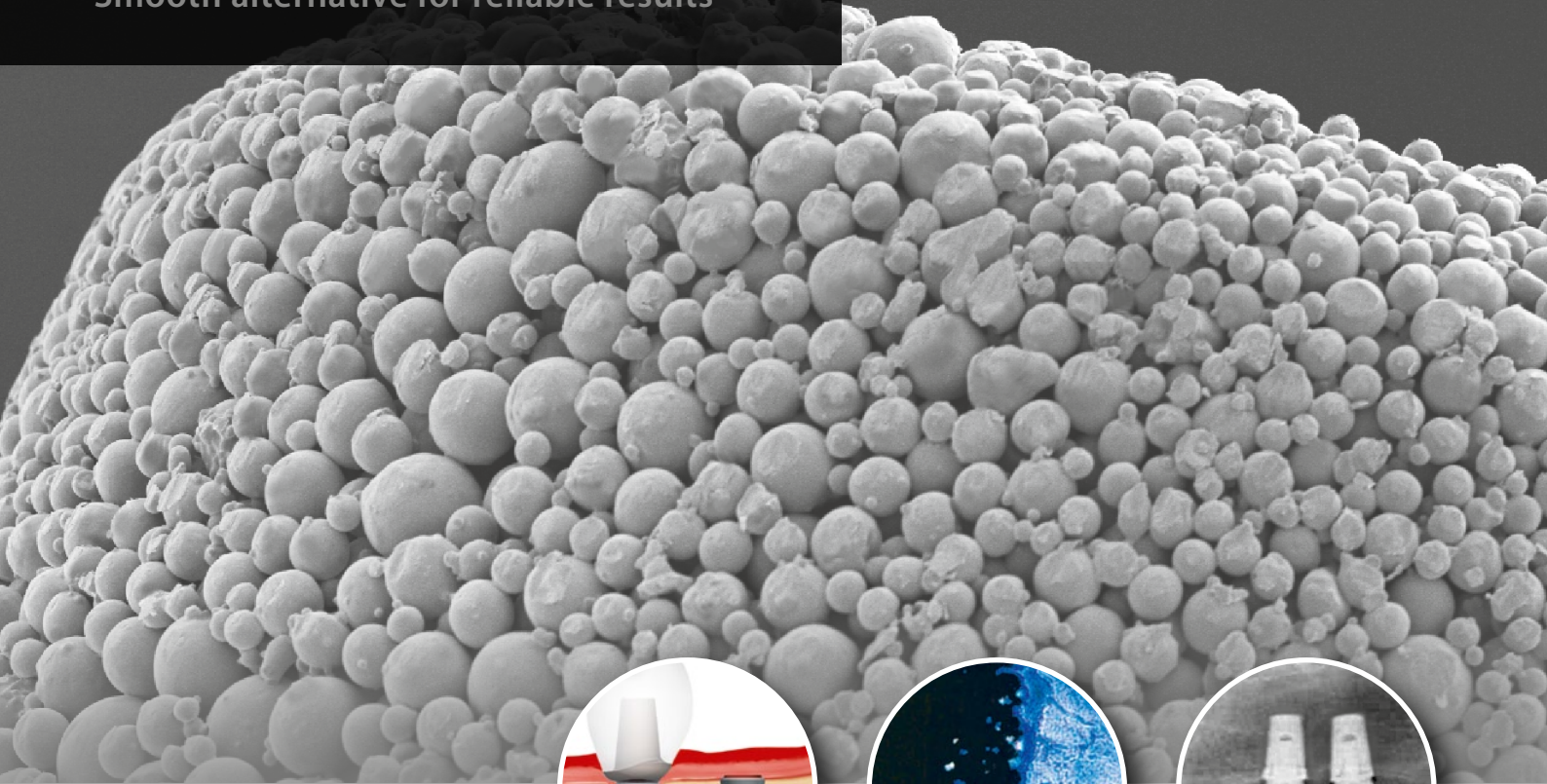

- **SHORT, CONICAL PRESS-FIT IMPLANT**
for insertion within limited vertical bone
- **SINTERED, POROUS SURFACE**
allows bone to grow into the entire three-dimensional surface structure
- **UNIQUE SURFACE TOPOGRAPHY**
allows a crown-root-ratio of 2:1 and single tooth replacement
- **COMPACT AND CLEAR SURGICAL CASSETTE**
for cutting drills, compressing osteotomes and cutting osteotomes for the internal sinus lift

OT-F³ IMPLANT SYSTEM

Implant overview

OT-F³ Press-Fit Implant

Implant design

OT-F³ is a conical, two-phase implant rounded at the apical diameter, which is inserted by tapping down to bone level. With its unique surface topography, the short, conical press-fit implant allows prosthetic restoration with low vertical bone availability and a crown-root ratio of 2:1.

Implant surface

The sintered porous surface allows bone to grow into the entire three-dimensional surface structure and so is primarily responsible for reliable osseointegration.

Indications

In addition to the extensive range of indications of the OT-F² screw implant the OT-F³ implant is to be used in long term healed bone in those severely atrophied jaw sections of the posterior mandible above the mandibular nerve (inferior alveolar nerve) and used in the maxilla below the maxillary sinus. OT-F³ implants should not be inserted in severely cortical bone (D1) because of the reduced blood support.

Important: A transgingival healing is not permitted with the OT-F³ implants!

Characteristics of short implants

- Indication in reduced vertical bone, but with adequate bone width in the posterior region of the maxilla and mandible
- Reduced risk of intra-operative complications
- Reduced physical and mental stress by avoiding costly surgical augmentation
- Reduction of an associated financial burden
- High patient satisfaction
- Short implants in recent studies obtain the same success rates as long implants

If you find this pictograph please note, that the product concerned is to be used only for the OT-F³ implant system.



Material: Titanium grade 5

Diameter	Length	Art. No.
3.80 mm ●	7 mm	03-1383070010
3.80 mm ●	9 mm	03-1383090010
4.10 mm ●	5 mm	03-1413050010
4.10 mm ●	7 mm	03-1413070010
4.10 mm ●	9 mm	03-1413090010
5.00 mm ●	5 mm	03-1503050010
5.00 mm ●	7 mm	03-1503070010
5.00 mm ●	9 mm	03-1503090010

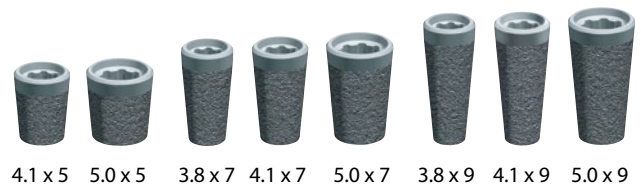

„Take care“-Patient set, pack of 10

09-700370001

Small zipper bag with important information what to do after insertion, incl. accessories for patients



Note

M1.6
M1.8

The OT-F³ implants \varnothing 3.80 have inner threads of the size M1.6, the implants \varnothing 4.10/5.00 mm size M1.8.





OT-F²/OT-F³ IMPLANT SYSTEM

Implant packing

The color coding system

The implant systems OT-F² and OT-F³ are provided in different diameters and lengths in order to cover multiple indications. The shared color coding facilitates the access to the individual components for the implantology team.

All Surgical Drills, Trial Fit Gauges, Implant Drivers, Cover Screws, Healing Abutments and Impression Copings as well as all abutments are color coded for all diameters.

Diameter	Color code	Color markings
3.40 mm	green	 
3.80 mm	yellow	
4.10 mm	red	
5.00 mm	blue	



OT-F²/OT-F³ IMPLANT SYSTEM

Implant packing

Packaging

The packaging and the labelling provide valuable information about the enclosed product before opening, such as: sterilization expiry date, surface type, implant length and diameter, article and lot number. The lot number assures traceability of all relevant product information and is required for any returns or warranty claims.

The packaging contains the Instructions for Use with important instructions as to how the implant should be inserted, as well as adhesive stickers which can be used in the documentation of patient records or with the implant passport.

The implant is delivered in a gamma sterile packaging which includes the appropriate Cover Screw.

The OT-F² implant is mounted onto an Implant Driver with a latch attachment within the packaging. For mechanical insertion, the latch attachment of the Implant Driver is directly fixed into the hand piece, whereas for manual insertion a corresponding Adapter is available.



- **For mechanical insertion:**
Removal of the implant through attachment of the Implant Driver into the hand piece

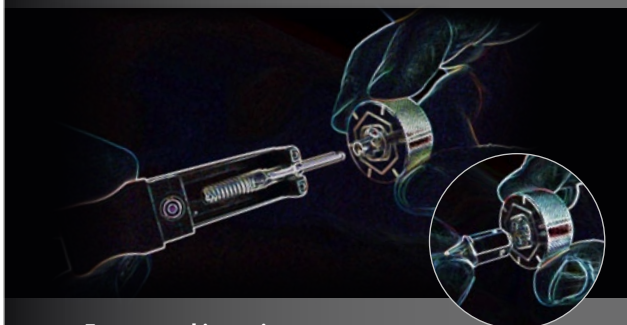

- **For manual insertion**
Removal of the implant through attachment of the Adapter (No. 02-7009006500) into the Finger Key

The OT-F³ implant is delivered on a transport pin with a push-out function. This allows easy placement of the implant into the prepared site.

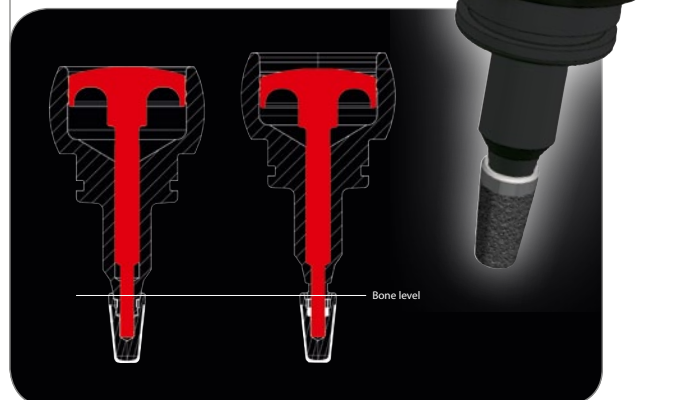

For more information, refer to the Instruction for Use contained in the implant package.



OT-F² IMPLANT SYSTEM

Surgery – Surgical Tray

Features

- Precise drilling concept with congruently sized drills and Drill Stops
- Effective and self-explanatory drill protocol
- Easy positioning after use and cleaning



The OT-F² drill protocol allows a simple, safe and time-efficient procedure within the daily workflow.

The combination of conical and Final Drills constitutes an innovative drill design which assures a unique cutting geometry and efficiency. The new OT-F² Final Drills can be completed with a Drill Stop to comply with the individual implant lengths and to provide an optimum of safety for the implant surgeon.

The Surgical Tray is compact and well accessible, contains all drills and tools for insertion of the OT-F² implants from 3.40 mm to 5.00 mm diameter.

The self-explanatory graphics shows the surgical process and facilitates the correct positioning after use and cleaning. The logical positioning of instruments in the compact Surgical Tray allows intuitive handling and therefore offers easier workflow and a saving of time for user and team.







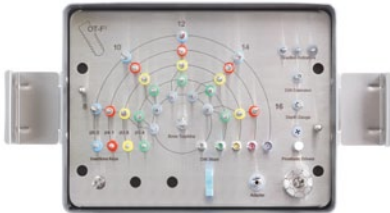

OT-F² IMPLANT SYSTEM

Surgery – Surgical Tray

SURGERY

OT-F² Surgical Tray - Content

	Description	Art. No.
	OT-F² Surgical Tray , complete	02-8009002110
	Content:	
	Surgical cassette OT-F ² , empty	02-8009001110
Pilot Drill ●		
	PD OT-F2 ø 2.0 L8	8 mm
	PD OT-F2 ø 2.0 L10	10 mm
	PD OT-F2 ø 2.0 L12	12 mm
	PD OT-F2 ø 2.0 L14	14 mm
	PD OT-F2 ø 2.0 L16	16 mm
Final Drill 3.40 ●		
	FD OT-F2 ø 3.4 L8	8 mm
	FD OT-F2 ø 3.4 L10	10 mm
	FD OT-F2 ø 3.4 L12	12 mm
	FD OT-F2 ø 3.4 L14	14 mm
	FD OT-F2 ø 3.4 L16	16 mm
Final Drill 3.80 ●		
	FD OT-F2 ø 3.8 L8	8 mm
	FD OT-F2 ø 3.8 L10	10 mm
	FD OT-F2 ø 3.8 L12	12 mm
	FD OT-F2 ø 3.8 L14	14 mm
	FD OT-F2 ø 3.8 L16	16 mm
Final Drill 4.10 ●		
	FD OT-F2 ø 4.1 L8	8 mm
	FD OT-F2 ø 4.1 L10	10 mm
	FD OT-F2 ø 4.1 L12	12 mm
	FD OT-F2 ø 4.1 L14	14 mm
	FD OT-F2 ø 4.1 L16	16 mm
Final Drill 5.00 ●		
	FD OT-F2 ø 5.0 L8	8 mm
	FD OT-F2 ø 5.0 L10	10 mm
	FD OT-F2 ø 5.0 L12	12 mm
	FD OT-F2 ø 5.0 L14	14 mm





– continuation page 14 –



OT-F² IMPLANT SYSTEM

Surgery – Surgical Tray

OT-F² Surgical Tray - Content

	Description	Art. No.
	Drill Stop Set with each 1 Drill Stop for PD ø 2.00, FD ø 3.40/3.80/4.10/5.00	02-7209002400
Implant Driver – With latch for contra-angle		
	Diameter 3.40 mm ●	02-7349086000
	Diameter 3.80 mm ●	02-7389086000
	Diameter 4.10 mm ●	02-7419086000
	Diameter 5.00 mm ●	02-7509086000

Note

The following older contra-angles/hand-pieces are **not compatible** with these Implant Drivers provided with a W&H Hexagon Chucking system at the shaft:

- Nouvag Type: CA 16:1 (SN: 5060 - SN: HD 1928)
- KAVO Type: 67 HC reduced 2:1 external cooling
- KAVO Type: 67 IC reduced 2:1 internal cooling
- Dyna Type: Dyna-Surg 18:1

– continuation page 15 –









OT-F² IMPLANT SYSTEM

Surgery – Surgical Tray

SURGERY

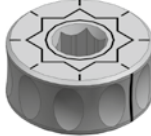
OT-F² Surgical Tray - Content

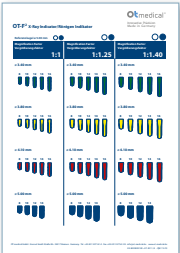
	Description	Art. No.
	Direction Indicator	01-7009007400
	Depth Gauge 2.0	02-7009007140
	Prosthetic Driver 1.30 mm Hex medium 12 mm shaft length	02-7139126010
	Adapter from latch attachment to Finger Key and Torque Wrench	02-7009006500
	Finger Key ø 20.0 mm	01-7009005200
	Drill Extension*	01-7009004200
	X-Ray Indicator OT-F² transparent template for placement on a panoramic radiograph for determining the implant diameter and length Magnification factor : 1:1/1:1.25/1:1.40	02-8009003100



OT-F³ IMPLANT SYSTEM

Surgery – Surgical Tray

Features

- OT-F³ Drills of new generation
- Simplified and time efficient Drill concept
- Effective and self-explanatory Drill protocol, intuitive handling
- Simple positioning of components after use and cleaning



Picture shows complete OT-F³ Surgical Tray including OT-F³ Extension set „Sinus lift“

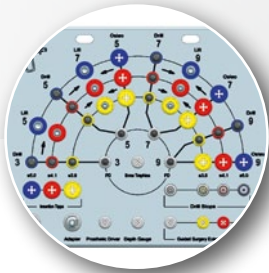

The creatively completely renewed OT-F³ Surgical Tray contains all the components for an implant bed preparation: cutting Drill for the preparation of the cortical bone (D1/D2), compressing Osteotome for condensation of spongy bone (D3/D4) and all the necessary auxiliary tools for the insertion of OT-F³ implants. The apically concave cutting Osteotomes for the internal sinus lift may be added.

Through the advanced drill design, with optional Drill Stops, intra-operative safety is guaranteed at its utmost.

The self-explanatory graphics shows the surgical process and facilitates the correct positioning after use and cleaning. The logical positioning of instruments in the compact Surgical Tray allows intuitive handling and therefore offers easier workflow and a saving of time for user and team.











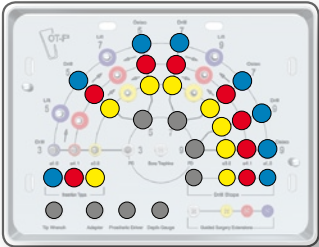

OT-F³ IMPLANT SYSTEM

Surgery – Surgical Tray

SURGERY

OT-F³ Surgical Tray - Content

	Description	Art. No.
	OT-F³ Surgical Tray, complete	03-8009002110
	Content:	
	Surgical cassette OT-F ³ , empty	03-8009001110
Pilot Drill 		
	PD OT-F3 L5	5 mm
	PD OT-F3 L7	7 mm
	PD OT-F3 L9	9 mm
Final Drill 3.80 		
	FD OT-F3 ø 3.8 L5	5 mm
	FD OT-F3 ø 3.8 L7	7 mm
	FD OT-F3 ø 3.8 L9	9 mm
Final Drill 4.10 		
	FD OT-F3 ø 4.1 L5	5 mm
	FD OT-F3 ø 4.1 L7	7 mm
	FD OT-F3 ø 4.1 L9	9 mm
Final Drill 5.00 		
	FD OT-F3 ø 5.0 L5	5 mm
	FD OT-F3 ø 5.0 L7	7 mm
	FD OT-F3 ø 5.0 L9	9 mm
	Drill Stop	03-7209002400
	Set with each 1 Drill Stop for PD, FD ø 3.80/4.10/5.00	













– continuation page 18 –



OT-F³ IMPLANT SYSTEM

Surgery – Surgical Tray

OT-F³ Surgical Tray - Content

	Description	Length	Art. No.
Trial Fit Gauge - convex 3.80 ●			
	Diameter max. 3.60 mm	5 mm	03-7389056100
	Diameter max. 3.60 mm	7 mm	03-7389076100
	Diameter max. 3.60 mm	9 mm	03-7389096100
Trial Fit Gauge - convex 4.10 ●			
	Diameter max. 3.90 mm	5 mm	03-7419056100
	Diameter max. 3.90 mm	7 mm	03-7419076100
	Diameter max. 3.90 mm	9 mm	03-7419096100
Trial Fit Gauge - convex 5.00 ●			
	Diameter max. 4.80 mm	5 mm	03-7509056100
	Diameter max. 4.80 mm	7 mm	03-7509076100
	Diameter max. 4.80 mm	9 mm	03-7509096100
	Insertion Tip 3.80 ●		03-7389006200
	Insertion Tip 4.10 ●		03-7419006200
	Insertion Tip 5.00 ●		03-7509006200

– continuation page 19 –









OT-F³ IMPLANT SYSTEM

Surgery – Surgical Tray

SURGERY

OT-F³ Surgical Tray - Content

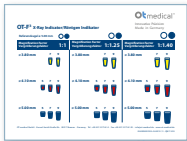







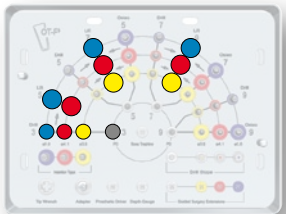

	Description	Art. No.
	Tip Wrench	03-7009006100
	Depth Gauge	03-7009007140
	Prosthetic Driver 1.30 mm Hex Latch for contra-angle	02-7179003000
	Adapter from latch attachment to Finger Key and Torque Wrench	02-7009006500
	Osteotome Hammer**	03-7009006200
	Osteotome Handle, straight	03-7009006300
	Osteotome Handle, bended	03-7009006400
	X-Ray Indicator OT-F³ transparent template for placement on a panoramic radiograph for determining the implant diameter and length Magnification factor : 1:1/1:1.25/1:1.40	03-8009003100

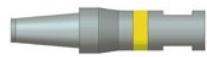

OT-F³ IMPLANT SYSTEM

Surgery – Extension set „Sinus lift“

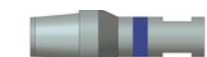
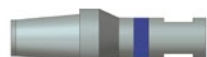
Sinus lift Instruments – Optionally expandable







	Description	Length	Art. No.
	OT-F³ Extension set „Sinus lift“ (Surgical cassette not included)		03-8009002510
CONTENT:			
	Pilot Drill ● PD OT-F3 L3	3 mm	03-7009032100
	Final Drill 3.80 ● FD OT-F3 ø 3.8 L3	3 mm	03-7389032110
	Final Drill 4.10 ● FD OT-F3 ø 4.1 L3	3 mm	03-7419032110
	Final Drill 5.00 ● FD OT-F3 ø 5.0 L3	3 mm	03-7509032110
Osteotome Tip – concave, cutting 3.80 ●			
	Diameter max. 3.60 mm	7 mm	03-7389076800
	Diameter max. 3.60 mm	9 mm	03-7389096800
Osteotome Tip – concave, cutting 4.10 ●			
	Diameter max. 3.90 mm	5 mm	03-7419056800
	Diameter max. 3.90 mm	7 mm	03-7419076800
	Diameter max. 3.90 mm	9 mm	03-7419096800
Osteotome Tip – concave, cutting 5.00 ●			
	Diameter max. 4.80 mm	5 mm	03-7509056800
	Diameter max. 4.80 mm	7 mm	03-7509076800
	Diameter max. 4.80 mm	9 mm	03-7509096800

OT-F²/OT-F³ IMPLANT SYSTEM

SURGERY

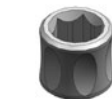
Surgery – Instruments

Additional Instruments & Accessories

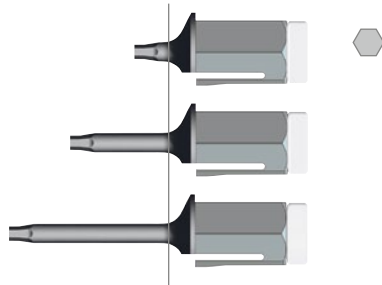
	Description	Art. No.
	Bone Trephine For removal of the periost tissue, smoothing and adjusting of the alveolar crest	01-7009004100
	Torque Wrench* Adjustable: 10/15/20/25/30 Ncm/∞	01-7009007600
	Finger Key ø 10.0 mm	01-7009005100
	Center Punch 3.50 mm For manual reentry of the gingiva	01-7009007100
	Drill Extension * (included in OT-F ² Surgical Tray)	01-7009004200
	Prosthetic Driver 1.30 mm Hex Latch for contra-angle short 7,2 mm long 13,5 mm (included in OT-F ³ Surgical Tray)	02-7179002000 02-7179003000
	Prosthetic Driver 1.30 mm Hex Connection for Torque Wrench and Finger Key short 6 mm shaft length medium 12 mm shaft length (included in OT-F ² Surgical Tray) long 18 mm shaft length	02-7139066010 02-7139126010 02-7139186010
Accessories: Surgical Tray, replacement filter , set of 100 pcs	01-8009001101	

OT-F²/OT-F³ IMPLANT SYSTEM

Prosthetic overview



Prothetische Aufbauten

The compatibility of both systems OT-F² and OT-F³ regarding prosthetic components contributes to a clear arrangement and user friendliness. Thus the prosthetic line is easily understandable and less cost intensive.

The system offers constructions from single tooth replacement to small and also large bridges up to an edentulous jaw reconstruction in different variations. If cemented, screw-fixed or removable by the dentist, the denture may be standard, individually custom-made or highly esthetic, everything is possible.

Please see detailed information on the following pages.

All inclusive

The following prosthetic abutments CreativeLine, VersaLine, NaturalLine, GoldLine, HighLine, CeraLine and ProfiLine Bar-Connector presented on the next few pages are packed with a mounted Laboratory Screw and an additional color coded Final Screw.

The Final Screw is contained in the sealing cap of the acrylic vial. Please only use this Final Screw for the final fixation of the abutments in the patient's mouth.

Please note!

An exception to the 4plus6Line abutments is, that they are delivered already assembled with the corresponding Final Screw due to their intra-operative use.

Following symbols are mentioned next to the abutments:



Abutments with rotation lock

These prosthetic lines have a square connection, which can be placed in 8 different rotation positions in the FourByFour® connection of the implant. Due to this connection the abutments are rotation locked.



Abutments without rotation lock

These abutments have no rotation lock and are therefore not to be used for the prosthetic restoration of single crowns.



Direction of angulation

An additional arrow shows the direction of angulation of the abutment (NaturalLine)

Prosthetic lines			Torque	Catalog	Restorations
	CreativeLine <i>Temporary abutment</i>	For temporary restoration and design of the emergence profile	15 Ncm	page 28	✓ Crowns/Bridges – cement retained
	CeraLine <i>Zirconium abutment</i>	High quality zirconium standard abutment with titanium base for the preparation of individual zirconium abutments	35 Ncm	page 28	✓ Crowns/Bridges – cement retained
	GoldLine <i>Gold base abutment</i>	Cast-on Abutment for preparation of individual abutments in precious metal alloys	35 Ncm	page 29	✓ Crowns/Bridges – cement retained ✓ Crowns/Bridges – screw retained ✓ Telescope-Restorations
	NaturalLine <i>Anatomical titanium abutment</i>	For the restoration of cemented crowns and bridges	35 Ncm	page 30	✓ Crowns/Bridges – cement retained
	VersaLine <i>Massive titanium abutment</i>	For the preparation of individual abutments by trimming, especially for the telescope and conical crown technique	35 Ncm	page 32	✓ Crowns/Bridges – cement retained ✓ Telescope-Restorations
	CAD/CAM <i>Scanbodies</i>	Auxiliary tool for registration of the implant positions	hand tight	page 33	✓ CAD/CAM
	HighLine <i>CAD/CAM abutment</i>	High quality abutment with titanium base for preparation of individual hybrid abutments or hybrid crowns	35 Ncm	page 34	✓ Crowns/Bridges – cement retained ✓ Telescope-Restorations ✓ CAD/CAM
	HighLine "C" <i>CAD/CAM abutment</i>	Hochwertiger Aufbau mit Titanbasis für das Chairside-Verfahren	35 Ncm	page 34	✓ CAD/CAM
	CAD/CAM <i>Preform</i>	Massive titanium abutment for individual milled titanium abutments by CAD/CAM methods	35 Ncm	page 35	✓ CAD/CAM
	4plus6 Line <i>Multi Unit abutment</i>	For restoration of edentulous jaws with 4 or 6 implants	35 Ncm (25 Ncm*; Cylinder)	page 36	✓ Bridges – screw retained ✓ Bar-Restorations ✓ CAD/CAM
	ProfiLine <i>Bar head abutment (one or two-part)</i>	Abutment for compensation of divergence for preparation of confectioned and individual bar constructions	35 Ncm	page 38	✓ Bar-Restorations ✓ Bridges – screw retained ✓ CAD/CAM
	TecLine <i>Ball head abutment</i>	For anchorage of complete prostheses with O-Ring or Dalbo® Plus elliptic attachments	35 Ncm	page 39	✓ Full Dentures
	LOCATOR® <i>Locator® abutment</i>	For anchorage of complete prostheses with original LOCATOR® retention elements (Manufacturer: Zest Anchors; USA)	35 Ncm	page 40	✓ Full Dentures
	Titanmagnetics® <i>Magnetic abutment</i>	For anchorage of complete prostheses with original counter-magnets (Manufacturer/Distributor: Steco; Hamburg)	35 Ncm	page 42	✓ Full Dentures

*25 Ncm concerns Cylinder with temporary treatment/ immediat loading of Multi Unit abutment

OT-F²/OT-F³ IMPLANT SYSTEM

Impression and master cast

Healing Abutment

Approx. 2 weeks prior to the final healing time, the implant sites can be reentered, the Cover Screws removed and replaced by Healing Abutments. The height of the Healing Abutments should be selected to protrude over the surrounding gingival tissue.

Available in three different variations:

- Healing Abutment „Standard“ (straight)

- Recommended for the usage of a TecLine Ball head abutment (page 39) or ProfiLine Bar abutment (page 38)

- Healing Abutment „Standard“ (flared)

- For slim mucosal thickness.

If the maximum emergence profile of the implant crown is to remain slightly above the implant shoulder.

The use of a Natualline GH 1.2 (page 31) or VersaLine GH 7.5 (page 32) mm is recommended for the final treatment.

- Healing Abutment „Slim“ (flared)

- For thick gingival height.

The design of the subgingival slim shape directly below the emergence into the oral cavity favors a maximal emergence profile. We recommend for the final abutment the use of a Natualline GH 3.5 (page 31) or a VersaLine GH 11 mm (page 32).

Material: Titanium grade 5

Torque: 15 Ncm



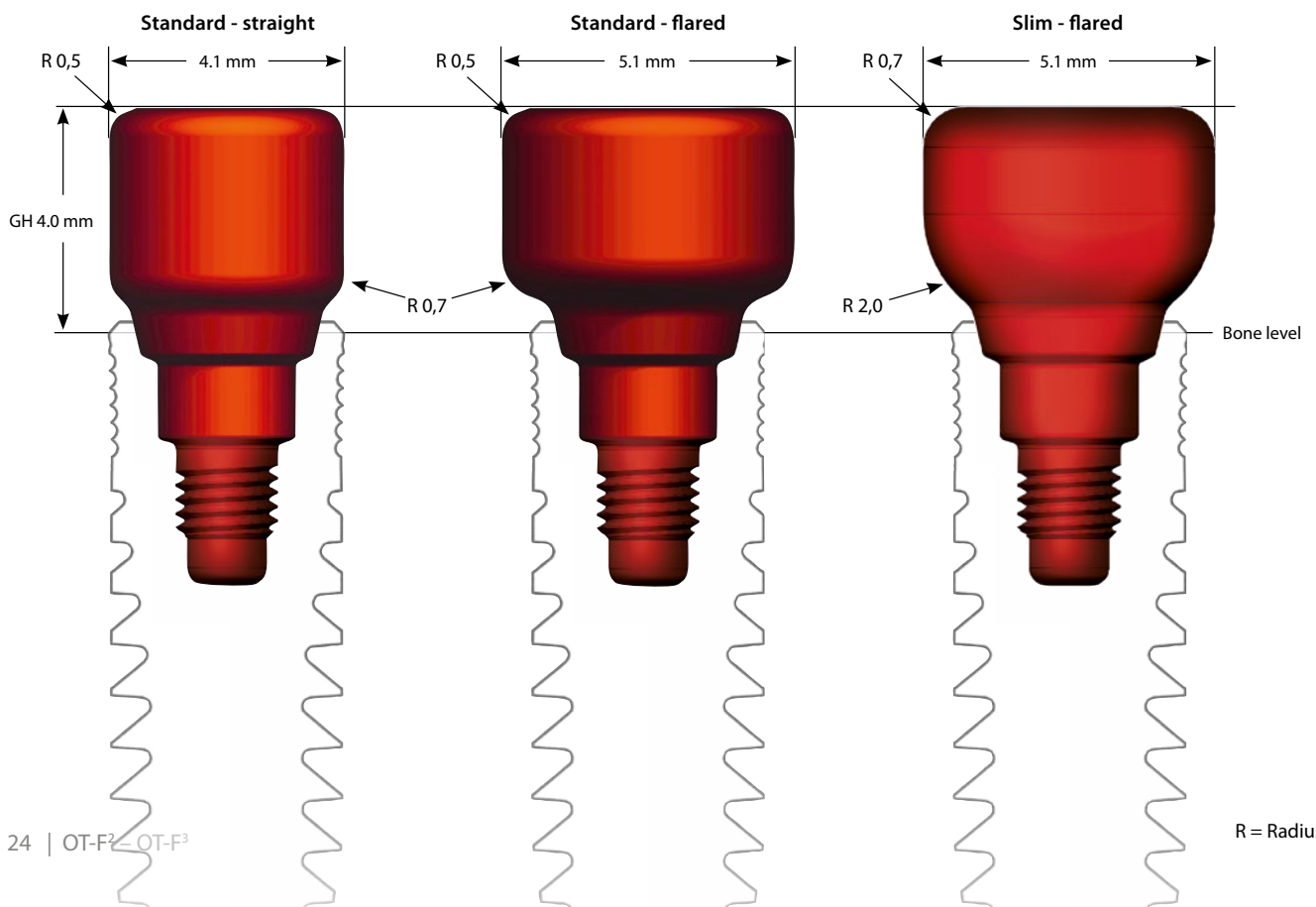













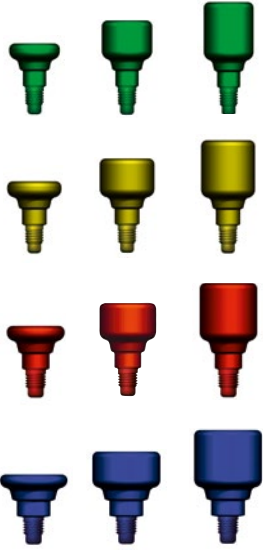











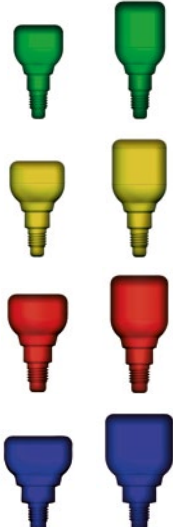

Example Ø 4.10 mm, GH 4.0 mm



OT-F²/OT-F³ IMPLANT SYSTEM

Impression and master cast



	Diameter		Gingiva height	Art. No.	
Standard - straight 	3.40 mm	 	GH 4.00 mm	02-2349042710	
	3.80 mm		GH 4.00 mm	02-2389042710	
	4.10 mm		GH 4.00 mm	02-2419042710	
	5.00 mm		GH 4.00 mm	02-2509042710	
	<hr/>				
Standard - flared 	3.40 mm		GH 2.00 mm	02-2349022610	
	3.40 mm		GH 4.00 mm	02-2349042610	
	3.40 mm	 	GH 6.00 mm	02-2349062610	
	<hr/>				
	3.80 mm		GH 2.00 mm	02-2389022610	
	3.80 mm		GH 4.00 mm	02-2389042610	
	3.80 mm		GH 6.00 mm	02-2389062610	
	<hr/>				
	4.10 mm		GH 2.00 mm	02-2419022610	
	4.10 mm		GH 4.00 mm	02-2419042610	
	4.10 mm		GH 6.00 mm	02-2419062610	
	<hr/>				
5.00 mm		GH 2.00 mm	02-2509022610		
5.00 mm		GH 4.00 mm	02-2509042610		
5.00 mm		GH 6.00 mm	02-2509062610		
<hr/>					
Slim - flared 	3.40 mm		GH 4.00 mm	02-2349042611	
	3.40 mm	 	GH 6.00 mm	02-2349062611	
	<hr/>				
	3.80 mm		GH 4.00 mm	02-2389042611	
	3.80 mm		GH 6.00 mm	02-2389062611	
	<hr/>				
	4.10 mm		GH 4.00 mm	02-2419042611	
	4.10 mm		GH 6.00 mm	02-2419062611	
	<hr/>				
	5.00 mm		GH 4.00 mm	02-2509042611	
5.00 mm		GH 6.00 mm	02-2509062611		

OT-F²/OT-F³ IMPLANT SYSTEM

Impression and master cast



Impression Coping

Both impression methods – the open and the closed – are used approx. 2 weeks after reentry. For impression taking, the Healing Abutment is removed from the implant and the Impression Coping is placed with the FourByFour®-connection into the implant and fixed with the corresponding Screw (1.30 mm hex).

For the Impression Coping “Closed Tray” acrylic Transfer Copings are included and should be used for the clear and precise place-

ment in the impression material (one way only). Furthermore, as a rule, we recommend using an individual impression tray.

Material: Titanium grade 5

Torque: 10 Ncm



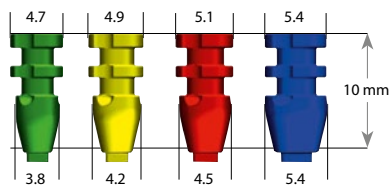

Open Tray

Incl. Screw



Diameter

Art. No.

3.40 mm			02-6349003010
3.80 mm			02-6389003110
4.10 mm			02-6419003110
5.00 mm			02-6509003110



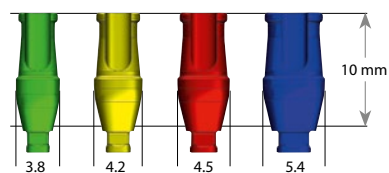

Closed Tray

Incl. Screw and Transfer Coping



Diameter

Art. No.





3.40 mm			02-6349002010
3.80 mm			02-6389002010
4.10 mm			02-6419002010
5.00 mm			02-6509002010

Transfer Coping



Diameter

Art. No.

3.40 mm			pack of 5	02-6349004000
3.80 mm			pack of 5	02-6389004000
4.10 mm			pack of 5	02-6419004000
5.00 mm			pack of 5	02-6509004000

OT-F²/OT-F³ IMPLANT SYSTEM

PROSTHETICS

Impression and master cast

Implant Analog

For setting up of the master model the Implant Analog and the Impression Coping have to be screwed together. With effected Open Tray Impression the color coded Implant Analog is affixed to the Impression Coping within the impression.

Through the perforation of the impression tray the Impression Coping Screw will be screwed onto the Implant Analog by the use of the Prosthetic Driver 1.3 mm Hex.

When a Closed Tray Impression has been taken, the color coded Implant Analog is screwed onto the Impression Coping separately from the impression tray.

As next step, the Implant Analog is placed back into the color coded Transfer Coping. We recommend to manufacture a removable gingiva mask to control the passive fit of the prosthetic superstructure.

Material: Titanium grade 5

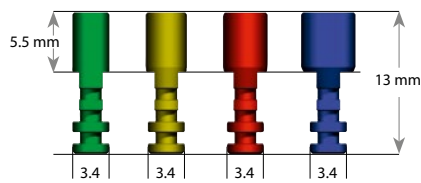

Diameter

Art. No.

3.40 mm	●		02-6349001000
3.80 mm	●		02-6389001000
4.10 mm	●		02-6419001000
5.00 mm	●		02-6509001000

OT-F²/OT-F³ IMPLANT SYSTEM

Prosthetic Components



CreativeLine (Temporary Abutment)

The CreativeLine titanium abutment is used for the preparation of temporary crowns or also for bridge restorations.

The engaged abutment (FourByFour®) is secured onto the implant with the abutment screw. The rounded (engrailed) abutment shaft is then covered with opaque. The thin, funnel type form places the user in the position to provide a natural emergence profile through the coated tooth-colored plastic material.

Ideally the temporary abutment should be placed immediately following implant exposure, at the site of the ready-made non-engaged titanium healing abutment. With the appropriate abutment form, it is also possible to secure a temporary crown to the site.

Material: Titanium grade 5

Torque: 15 Ncm

Incl. Final and Laboratory Screw

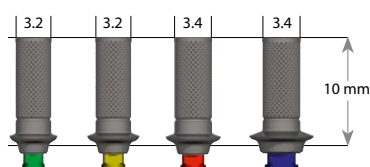

Diameter

Art. No.

3.40 mm	●		02-2349005510
3.80 mm	●		02-2389005510
4.10 mm	●		02-2419005510
5.00 mm	●		02-2509005510



CeraLine (Zirconia Abutment)

CeraLine is an abutment series of zirconium oxide abutment preforms, which can be individualized. The connection fixation to the implant is guaranteed through a highly precise titanium base. The Abutment Screw transfers the forces during final fixation to the titanium base, and not onto the zirconium part of the individualized abutment. The abutment is made of highly solid Yttrium stabilized zirconium oxide.

These preforms can be modified by trimming with a water cooled turbine. A veneering with suitable zirconium ceramics and color characterization is also possible. The final zirconium part is fixed onto the titanium base by adhesive after the above modifications have been made.

Material: Titanium grade 5 (Base), Zirconium oxide (Abutment)

Torque: 35 Ncm

Incl. Final and Laboratory Screw

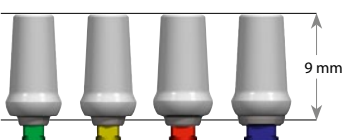

Diameter

Art. No.

3.40 mm	●		0°	02-5349003510
3.80 mm	●		0°	02-5389003510
4.10 mm	●		0°	02-5419003510
5.00 mm	●		0°	02-5509003510

OT-F²/OT-F³ IMPLANT SYSTEM

Prosthetic Components



GoldLine (Goldbase Abutment)

The GoldLine abutment is used for a large range of indications.

- Individual abutments for fixed crown and bridge treatment
- Individual primary parts in the telescope- and conical crown technique.

The basis of the abutment consists of a precisely constructed, cast-on gold-platinum alloy and shows a perfect fit to the implant. The color coded funnel, fixed onto the base, is made of burn-out acrylic.

Preparation:

The desired abutment shape is modeled onto the acrylic section, and the abutment is invested. In standard processing procedures, a precious metal alloy is casted onto the existing precious metal base.

Processing indications:

Melting interval: 1400 – 1490°C (2550-2710°F)
 Cast-on temperature: to 1350°C (2.462°F)





When removing, the precious metal base should be carefully cleaned with polishing blast pearls at a pressure of approx. 1.5 bar. Verification of the exact screw fit and the screw channel on possible remnants from casting should be done by using a microscope.

Material: Gold/Platinum alloy (Base), Plastic POM (Funnel)

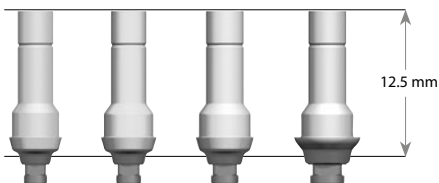
Torque: 35 Ncm

Incl. Final and Laboratory Screw



Diameter		PM-Weight	Art. No.
3.40 mm	● 	0,43 g	02-5349001010
3.80 mm	● 	0,52 g	02-5389001010
4.10 mm	● 	0,59 g	02-5419001010
5.00 mm	● 	0,67 g	02-5509001010

Note

Do not use telescope- and conical crowns on implants of the diameter 3.40 mm!

OT-F²/OT-F³ IMPLANT SYSTEM

Prosthetic Components

NaturalLine (Titanium Abutment)

The special feature of this abutment is a subgingival shape. This extends in a circular convex fashion, starting from the implant shoulder and ending in a wave-like, circular hollow groove which begins from the oral side swinging down to the esthetic side.

Different abutment variations are available:

- In 0° and angulations of 15° and 25°
- In socket heights (GH) 1.20 and 3.50 mm.

With the **lower versions** (GH 1.2) the maximum contour is reached soon above the emergence of the implant.

With the **higher versions** (GH 3.5) the abutment starts concave circular from the implant and then forms a convex shape supporting the surrounding gingival tissues.

The primary massive contour allows the user to reduce the abutment by using suitable tools (titanium trephines, polishers) and to design an optimal emergence profile.

Furthermore, an exact transition of the crown to be prepared is possible by the circular shoulder. The contour of the shoulder should be adjusted to the contour of the gingival tissue.

Material: Titanium grade 5

Torque: 35 Ncm

Example Ø 4.10 mm

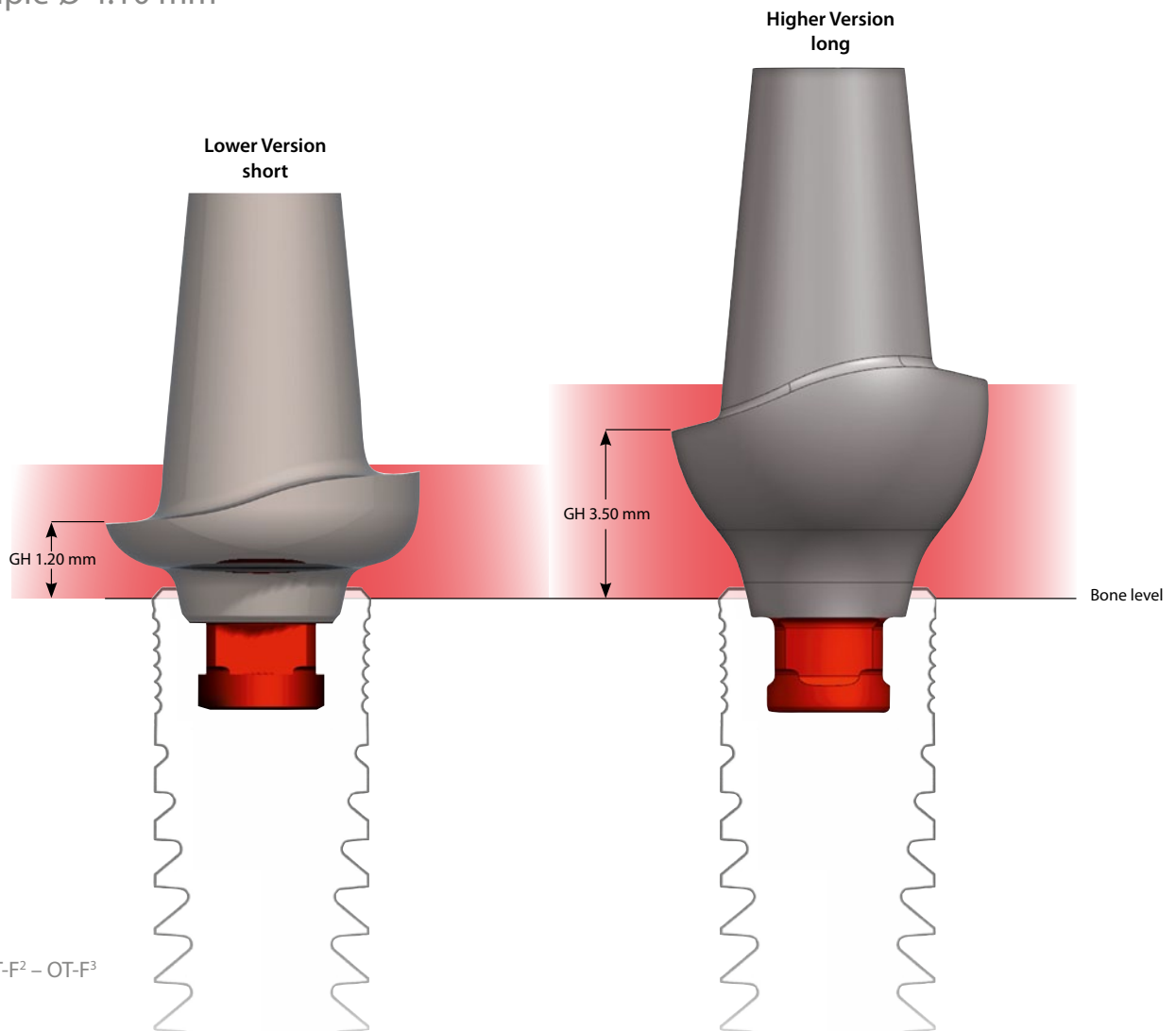

OT-F²/OT-F³ IMPLANT SYSTEM

Prosthetic Components



Lower Version - GH 1.2 - short

Incl. Final and Laboratory Screw	Diameter			Gingiva height	Art. No.	
	3.40 mm	●		0°	GH 1.20 mm	02-3349012510
	3.80 mm	●		0°	GH 1.20 mm	02-3389012510
	4.10 mm	●		0°	GH 1.20 mm	02-3419012510
	5.00 mm	●		0°	GH 1.20 mm	02-3509012510
	3.40 mm	●		15°	GH 1.20 mm	02-3349012110
	3.80 mm	●		15°	GH 1.20 mm	02-3389012110
	4.10 mm	●		15°	GH 1.20 mm	02-3419012110
	5.00 mm	●		15°	GH 1.20 mm	02-3509012110
	3.40 mm	●		25°	GH 1.20 mm	02-3349012310
	3.80 mm	●		25°	GH 1.20 mm	02-3389012310
	4.10 mm	●		25°	GH 1.20 mm	02-3419012310
	5.00 mm	●		25°	GH 1.20 mm	02-3509012310

Higher Version - GH 3.5 - long

	3.40 mm	●		0°	GH 3.50 mm	02-3349042510
	3.80 mm	●		0°	GH 3.50 mm	02-3389042510
	4.10 mm	●		0°	GH 3.50 mm	02-3419042510
	5.00 mm	●		0°	GH 3.50 mm	02-3509042510
	3.80 mm	●		15°	GH 3.50 mm	02-3389032110
	4.10 mm	●		15°	GH 3.50 mm	02-3419032110
	5.00 mm	●		15°	GH 3.50 mm	02-3509032110
	3.80 mm	●		25°	GH 3.50 mm	02-3389032310
	4.10 mm	●		25°	GH 3.50 mm	02-3419032310
	5.00 mm	●		25°	GH 3.50 mm	02-3509032310

When selecting the Healing Abutment, the user should be sure to have a corresponding shape congruence if he chooses the NaturalLine final abutment.

OT-F²/OT-F³ IMPLANT SYSTEM

Prosthetic Components



VersaLine (Titanium Abutment)

The VersaLine abutments offer multiple solutions for an individual preparation of

- Primary parts in the telescope and conical crown technique
- Abutments for the crown and bridge technique

The VersaLine abutment allows precise modifications to prepare angulations between 0 and nearly 25° and also the preparation of circular shoulders copying the natural contour of the gingival tissues. It is also possible to veneer the abutment directly with a suitable titanium ceramics.

We recommend the use of suitable titanium trephines for preparation of this abutment.

Important:

Please avoid the use of implants with a diameter of 3.40 mm for a restoration with telescope or conical crowns.

The VersaLine abutment is available in two different variations:

• 7.50 mm height

For small gingival height. Maximum emergence profile immediately above the implant shoulder.

We recommend the use of a standard Healing Abutment flared, prior to insertion of the final abutment.

• 11.00 mm height

For thick gingival height. The design of the subgingival slim shape directly below the emergence into the oral cavity favors an optimal emergence profile.

We recommend the use of a Healing Abutment "Slim" (flared) prior to insertion of the final abutment.

Material: Titanium grade 5

Torque: 35 Ncm

Incl. Final and Laboratory Screw

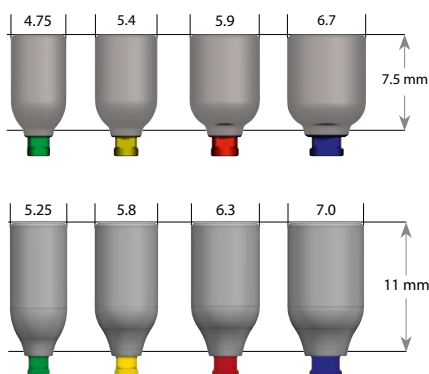

Diameter		Height	Art. No.
3.40 mm	●	7.50 mm	02-3349753510
3.40 mm	● 	11.00 mm	02-3349123510
3.80 mm	●	7.50 mm	02-3389753510
3.80 mm	●	11.00 mm	02-3389123510
4.10 mm	●	7.50 mm	02-3419753510
4.10 mm	●	11.00 mm	02-3419123510
5.00 mm	●	7.50 mm	02-3509753510
5.00 mm	●	11.00 mm	02-3509123510

Note

When selecting the Healing Abutment, the user should be sure to have a corresponding shape congruence if he chooses the VersaLine final abutment.

OT-F²/OT-F³ IMPLANT SYSTEM

Prosthetic Components



CAD/CAM Scanbodies

The scan body serves as an auxiliary tool for registration of the implant positions in the patients' mouth or of the implant analogs in the master model.

and manufacturing of milled onepiece or hybrid abutments as well as various bar constructions by CAD/CAM technique.

By scanning, this position is transferred precisely to the virtual 3D model, which is a prerequisite for the individual construction

Material: Titanium grade 5
Torque: hand tight

Incl. color-coded Screw



Diameter	Art. No.
3.4 mm ● 	02-6349006000
3.8 mm ●	02-6389006000
4.1 mm ●	02-6419006000
5.0 mm ●	02-6509006000

➔ CAD/CAM SCANBODIES

- with FourByFour® Interface
- for 4plus6Line (Multi Unit Abutment) (page 37)

- ✓ Reflection free surface
- ✓ Laser marking
- ✓ Suitable for laboratory- and intra-oral scanners
- ✓ Supplied with Abutment screw secured by internal threads

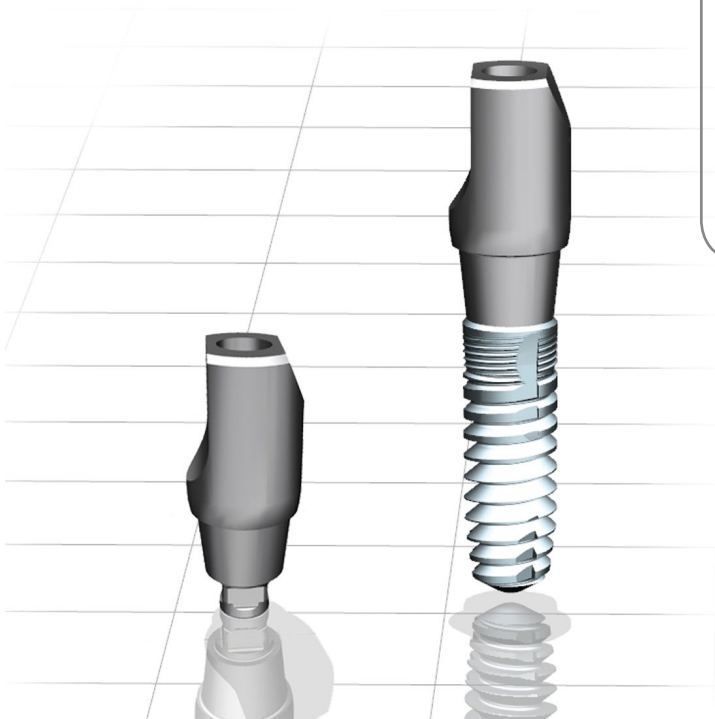

OT-F²/OT-F³ IMPLANT SYSTEM

Prosthetic Components



HighLine (CAD/CAM Abutment)

The HighLine abutment serves as base for the manufacture of individual zirconium abutments. The CAD/CAM as well as the copy milling procedure can be implemented with this abutment in an optimal way.

The connection with the implant is guaranteed through a highly precise titanium base. The Abutment Screw transfers the forces during final fixation to the titanium base, and not onto the zirconium part of the individualized abutment.

The rotational secure, acrylic funnel, supplied with the low version, serves as a wax up base for processing.

Material: Titanium grade 5 (Base), Acrylic POM (Funnel)

Torque: 35 Ncm / Scanbody: hand tight

Incl. Final and Laboratory Screw

Titanium base 3.0 mm incl. Acrylic funnel

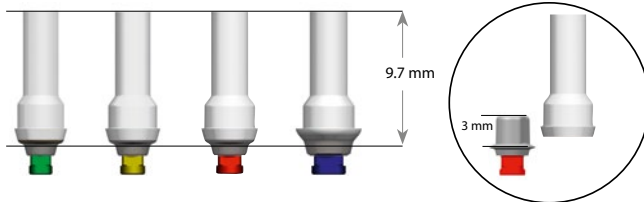

Diameter		Height Titanium base	Art. No.
3.40 mm		3.0 mm	02-5349002010
3.80 mm		3.0 mm	02-5389002010
4.10 mm		3.0 mm	02-5419002010
5.00 mm		3.0 mm	02-5509002010

Titanium base 5.5 mm (without Acrylic funnel)

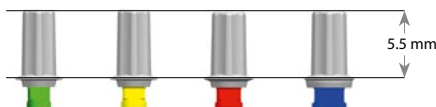

3.40 mm		5.5 mm	02-5349002310
3.80 mm		5.5 mm	02-5389002310
4.10 mm		5.5 mm	02-5419002310
5.00 mm		5.5 mm	02-5509002310

HighLine „C“ Titanium base (Incl. Final and Laboratory Screw)

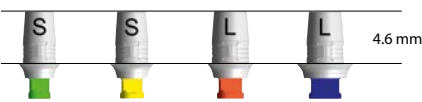

3.40 mm		S	4.6 mm	02-5349006010
3.80 mm		S	4.6 mm	02-5389006010
4.10 mm		L	4.6 mm	02-5419006010
5.00 mm		L	4.6 mm	02-5509006010

Scanbody „C“ (Incl. color-coded Screw)



3.40 mm		S		02-6349006110
3.80 mm		S		02-6389006110
4.10 mm		L		02-6419006110
5.00 mm		L		02-6509006110

OT-F²/OT-F³ IMPLANT SYSTEM

Prosthetic Components

PROSTHETICS



CAD/CAM Preforms

With CAD/CAM preforms any anatomically and prosthetically required shape may be realized by CAD/CAM technology in order to produce an individualized titanium abutment.

The virtual construction (CAD) of the abutment allows the individual design of the requested emergence profile, the profile of the circular shoulder as well as the desired dimension and angulation.

The individual patient-related titanium abutment is manufactured computer added by a milling machining (CAM) from the massive CAD/CAM preform. The pre-fabricated and highly precise FourBy-Four® connection guarantees a safe implant-abutment-interface.

Material: Titanium grade 5

Torque: 35 Ncm

CAD/CAM Preforms „M“ (Compatible with Medentika)

Incl. Laboratory and Final Screw

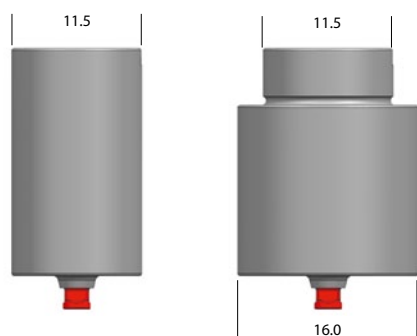

Impl. Diameter		Diameter	Art. No.
3.40 mm	●	11,5 mm	02-5349005010
3.80 mm	●	11,5 mm	02-5389005010
4.10 mm	●	11,5 mm	02-5419005010
5.00 mm	●	11,5 mm	02-5509005010
3.80 mm	●	16,0 mm	02-5389005110
4.10 mm	●	16,0 mm	02-5419005110
5.00 mm	●	16,0 mm	02-5509005110

CAD/CAM Preforms „CS“ (Compatible with CADstar)

Incl. Laboratory and Final Screw



Impl. Diameter		Diameter	Art. No.
3.40 mm	●	14,0 mm	02-5349005210
3.80 mm	●	14,0 mm	02-5389005210
4.10 mm	●	14,0 mm	02-5419005210
5.00 mm	●	14,0 mm	02-5509005210

Note

More information can be found in the download area of www.ot-medical.de

OT-F²/OT-F³ IMPLANT SYSTEM

Prosthetic Components

4plus6Line (Multi Unit Abutment)

The abutments of the 4plus6Line offer the opportunity to provide an implant solution with a fixed prosthesis using only 4 implants in an edentulous mandible or 6 implants in an edentulous maxilla.

The angulated insertion of the posterior implants allows the use of longer implants, whereas the local bone is optimally utilized.

For the user, components for the 4plus6Line are available in a straight 0° version as well as in the angulated versions with 17°

and 30°, each available in the gingival heights of 1.50 and 3.00 mm.

NOTE:

For intra-operative use, the below listed components are supplied in a sterile packaging and are delivered with a pre-mounted Final Screw.

Material: Titanium grade 5
Torque: 35 Ncm

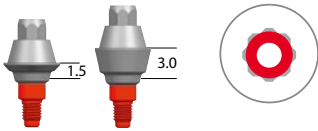
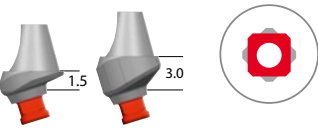
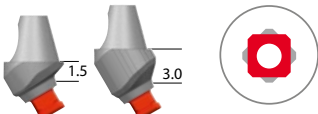
	Diameter	Angulation	Gingiva height	Art. No.
	3.80 mm ●	0°	GH 1.50 mm	02-4389014510
	3.80 mm ●	0°	GH 3.00 mm	02-4389034510
	4.10 mm ●	0°	GH 1.50 mm	02-4419014510
	4.10 mm ●	0°	GH 3.00 mm	02-4419034510
Incl. Final Screw (M1.6 for Ø 3.80/M1.8 for Ø 4.10)				
	3.80 mm ●	17°	GH 1.50 mm	02-4389014110
	3.80 mm ●	17°	GH 3.00 mm	02-4389034110
	4.10 mm ●	17°	GH 1.50 mm	02-4419014110
	4.10 mm ●	17°	GH 3.00 mm	02-4419034110
Incl. Final Screw (M1.8 for Ø 4.10)				
	4.10 mm ●	30°	GH 1.50 mm	02-4419014310
	4.10 mm ●	30°	GH 3.00 mm	02-4419034310

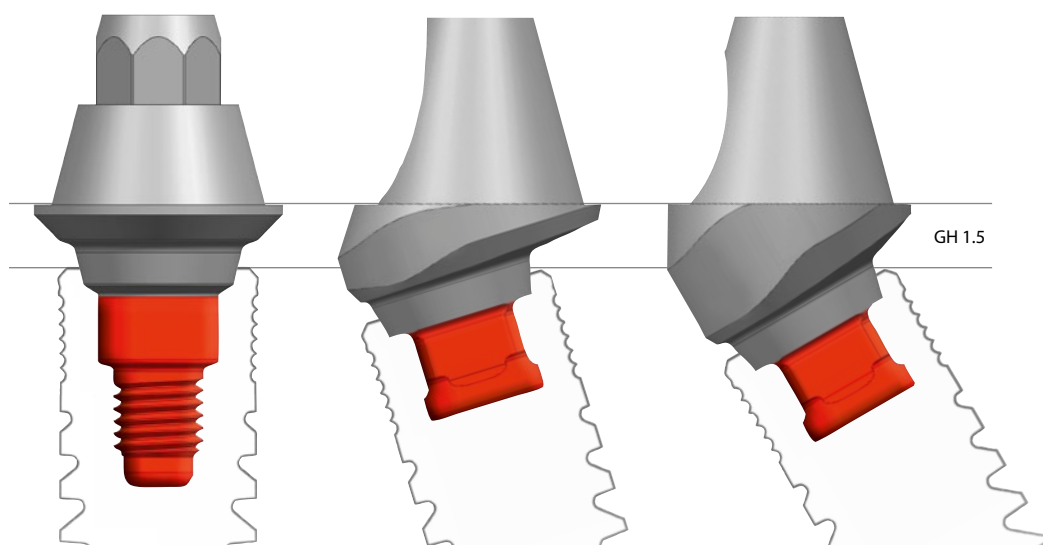





OT-F²/OT-F³ IMPLANT SYSTEM

Prosthetic Components

PROSTHETICS



Additional prosthetic components

	Article	Art. No.
	4plus6Line Healing Abutment Material: Acrylic Incl. Final Screw M1.4 for 4plus6Line	02-4009004110
	4plus6Line Impression Coping Incl. Impression Coping Screw M1.4, for 4plus6Line	02-4009004210
	4plus6Line Implant Analog	02-4009004310
	4plus6Line Cylinder POM 4plus6Line Cylinder Titanium Incl. Final and Laboratory Screw M1.4 for 4plus6Line Torque 25 Ncm	02-4009004410 02-4009004510

4plus6Line Scanbody

	4plus6Line Scanbody Incl. Scan Screw M1.4 for 4plus6Line, Length 5.2 mm	02-6009001500
---	---	---------------



OT-F²/OT-F³ IMPLANT SYSTEM

Prosthetic Components



ProfiLine (Bar Abutment)

The ProfiLine abutment consists of two parts, and serves in preparing prefabricated, as well as individually milled bar constructions. The first step is made with the selection of the 2.5 mm or 4.0 mm high Adapter specific to the diameter. This Adapter is fixed onto the implant in the mouth of the patient with the aid of the corresponding FourByFour® Implant Driver and tightened with a force of 35 Ncm. As the Adapter has the identical internal contour as the implant, the impression is taken at the Adapter level, followed by the placement of a Healing Abutment which remains in the mouth of the patient. In the case of minimal gingival height the Adapter can be avoided and the Bar Connector can be placed

directly onto the implant. In the second step the selection of the Bar Connector is made. Depending on the following preparation methods (cast-on; soldering; laser welding; glue) the titanium or precious metal Bar Connector is placed.

Through the conical connection between the Adapter and the Bar Connector, a divergence balance of up to 26° is possible between the implants.

Material: Titanium grade 5 (Adapter)

Torque: 35 Ncm

Bar Adapter

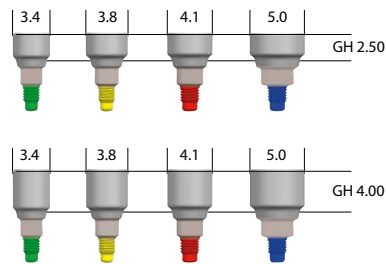

Diameter		Gingiva height	Art. No.
3.40 mm	●	GH 2.50 mm	02-4349022010
3.40 mm	●	GH 4.00 mm	02-4349042010
3.80 mm	●	GH 2.50 mm	02-4389022010
3.80 mm	●	GH 4.00 mm	02-4389042010
4.10 mm	●	GH 2.50 mm	02-4419022010
4.10 mm	●	GH 4.00 mm	02-4419042010
5.00 mm	●	GH 2.50 mm	02-4509022010
5.00 mm	●	GH 4.00 mm	02-4509042010

Incl. Final and Laboratory Screw

Bar Connector, Titanium grade 5 without rotation lock

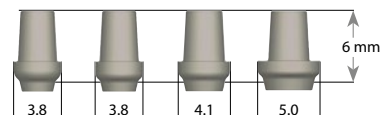

3.40 mm	●		02-4349002210
3.80 mm	●		02-4389002210
4.10 mm	●		02-4419002210
5.00 mm	●		02-4509002210

Bar Connector, Precious metal without rotation lock

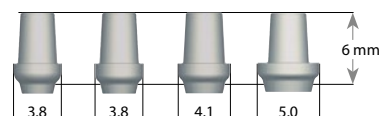

3.40 mm	●	PM weight 0,43 g	02-5349004010
3.80 mm	●	PM weight 0,45 g	02-5389004010
4.10 mm	●	PM weight 0,50 g	02-5419004010
5.00 mm	●	PM weight 0,73 g	02-5509004010

OT-F²/OT-F³ IMPLANT SYSTEM

Prosthetic Components

PROSTHETICS



TecLine (Ball Head Abutment)

The TecLine Abutment serves for anchorage of implant-supported full dentures. For anchoring, the user can choose between the O-Ring attachment and Retention Anchor Dalbo® Plus elliptic. At the O-Ring attachment at first a red O-ring is inserted into a titanium metal housing. This one remains in the housing during the laboratory processing, and is replaced by the second red O-ring for final insertion of the denture.

The Retention Anchor Dalbo® Plus elliptic consists of two parts: a titanium housing with retention wings for fixation in the denture, and therein a Lamellae Retention Insert screw-in, made of precious metal, for which the forces can be individually adjusted by using an Activator Key (200-1200g). Dalbo®-Plus elliptic can be used for up to 20° divergency of the implant.

Material Housing: Titanium grade 5
Torque: 35 Ncm

	Diameter		Gingiva height	Art. No.
	3.40 mm	●	2.00 mm	02-4349021010
	3.40 mm	●	4.00 mm	02-4349041010
	3.80 mm	●	2.00 mm	02-4389021010
	3.80 mm	●	4.00 mm	02-4389041010
	4.10 mm	●	2.00 mm	02-4419021010
	4.10 mm	●	4.00 mm	02-4419041010
	5.00 mm	●	2.00 mm	02-4509021010
	5.00 mm	●	4.00 mm	02-4509041010

TecLine Accessories

	Description	Art. No.
	O-Ring Housing, complete incl. O-Rings	01-4009001600
	O-Ring Housing	single 01-4009001100
	O-Ring black (higher retention),	pack of 4 01-4009001904
	O-Ring red	pack of 4 01-4009001204
	Retention Anchor „Dalbo® Plus elliptic” ** complete	01-4009001400
	Lamellae Retention Insert ** (precious metal)	single 01-4009001700
	Activator Key * for Retention Anchor Dalbo® Plus elliptic	01-4009001800
	Implant Analog for Ball Head Abutment	04-6009001300
	TecLine „Casting template”, made of burn-out acrylic	01-4009001500
	Driver Octagon Connection for Torque Wrench and Finger Key	01-7259106010

OT-F²/OT-F³ IMPLANT SYSTEM

Prosthetic Components

LOCATOR®

The Locator® Abutment is an attachment with a self-aligning function. This feature makes it easier for patients in the seating of their denture and eliminates additional wear from improper seating. With the Locator's vertical height at a minimum, it is ideal where interocclusal space is limited. This abutment can

also be used to compensate up to 40° divergency between two implants.



Material: Titanium with TiN coating

Torque: 35 Ncm



Diameter		Gingiva height	Art. No.
3.40 mm	●	 GH 1.00 mm GH 2.00 mm GH 3.00 mm	02-4349013010
3.40 mm	●		02-4349023010
3.40 mm	●		02-4349033010
<hr/>			
3.80 mm	●	GH 1.00 mm	02-4389013010
3.80 mm	●	GH 2.00 mm	02-4389023010
3.80 mm	●	GH 3.00 mm	02-4389033010
3.80 mm	●	GH 4.00 mm	02-4389043010
<hr/>			
4.10 mm	●	GH 1.00 mm	02-4419013010
4.10 mm	●	GH 2.00 mm	02-4419023010
4.10 mm	●	GH 3.00 mm	02-4419033010
4.10 mm	●	GH 4.00 mm	02-4419043010
<hr/>			
5.00 mm	●	GH 1.00 mm	02-4509013010
5.00 mm	●	GH 2.00 mm	02-4509023010
5.00 mm	●	GH 3.00 mm	02-4509033010
5.00 mm	●	GH 4.00 mm	02-4509043010

LOCATOR® Accessories









	Description	Article No.
	Locator® Male Processing Package Dual Retentive, Use in cases of 0° to 10° divergence 1 pack includes: 1 Denture Cap incl. Black Processing Male, 1 Replacement Male blue, pink, transparent, 1 Spacer white	pack of 2 02-4009004300 8519-2
	Locator® Male Processing Package for dual Retentive (0° to 10° divergence)	pack of 10 02-4009003200 8519-10
	Locator® Male Processing Package* Extended Range, Use in cases of 10° to 20° divergence 1 pack includes: 1 Denture Cap incl. Black Processing Male, 1 Replacement Male red, orange, green, 1 Spacer white	pack of 2 02-4009005100 8540

OT-F²/OT-F³ IMPLANT SYSTEM

Prosthetic Components

PROSTHETICS

LOCATOR® Accessories

	Description	Article No.
Material: Nylon		
Locator® Replacement Males		
Dual Retentive, Use in cases of 0° to 10° divergence		
	blue removal force approx. 680 g pack of 4	8547/02-4009003400
	pink removal force approx. 1.360 g pack of 4	8527/02-4009003300
	transparent removal force approx. 2.270 g pack of 4	8524/02-4009004400
LOCATOR® Replacement Males, pack of 4		
Extended Range, Use in cases of 10° to 20° divergence*		
	grey no retention pack of 4	8558/02-4009004700
	red removal force approx. 450 g pack of 4	8524/02-4009003600
	orange removal force approx. 907 g pack of 4	8915/02-4009004500
	green removal force approx. 1.810 g pack of 4	8547/02-4009003500
	LOCATOR® Processing Replacement Male black	pack of 4 8515/02-4009003100
	LOCATOR® Denture Cap Male	pack of 4 8510/02-4009005300
	LOCATOR® Parallel Post	pack of 4 8517/02-4009003700
	LOCATOR® Impression Coping Material: Aluminum	pack of 4 8505/02-4009003800
	LOCATOR® Implant Analog Material: Aluminum Diameter 4.00 mm	pack of 4 8530/02-4009003900
	LOCATOR® Angle Measurement Guide	9530/02-4009004000
	LOCATOR® Core Tool	8393/02-4009004100
	LOCATOR® Torque Wrench Driver	8317/02-4009004200

* Do not use these male parts for implants of 3.40 mm diameter!

OT-F²/OT-F³ IMPLANT SYSTEM

Prosthetic Components

Other Prosthetic components

Titanmagnetics from Steco

Especially elderly patients with manual or motoric restrictions profit from the easy insertion and removal of magnetically retained prostheses. Titanmagnetics are self-aligning and easy to clean.



Distributed by:

steco-system-technik GmbH & Co. KG
Kollastrasse 6, 2529 Hamburg, Germany
Phone +49 40 - 55 77 81-0





	Diameter		Gingiva height	Art. No.
3.40 mm ●	3.40 mm ●		X-Line 3.25 mm	I.56.03.X325
			K-Line 2.50 mm	I.56.03.K250
3.80 mm ●	3.80 mm ●		X-Line 3.25 mm	I.56.01.X325
			K-Line 2.50 mm	I.56.01.K250
4.10 mm ●	4.10 mm ●		X-Line 3.25 mm	I.56.02.X325
			K-Line 2.50 mm	I.56.02.K250

OT-F²/OT-F³ IMPLANT SYSTEM

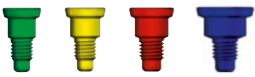

Prosthetic Components

PROSTHETICS

Cover Screw

Material: Titanium grade 5	Diameter	Art. No.
	3.40 mm ● 	02-2349001000
	3.80 mm ●	02-2389001000
	4.10 mm ●	02-2419001000
	5.00 mm ●	02-2509001000

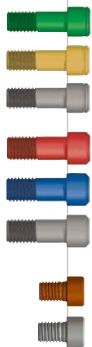
Prosthetic Screw

	Impression Coping Screw	
	M1.6, 18 mm (open) for ø 3.40 ●	02-8349194100
	M1.6, 18 mm (open) for ø 3.80 ●	02-8389194100
	M1.8, 18 mm (open) for ø 4.10 ●	02-8419194100
	M1.8, 18 mm (open) for ø 5.00 ●	02-8509194100
	M1.4, 4plus6Line (open)	02-8149194000
	Abutment Screws	
	Final Screw M1.6, Length 6 mm for ø 3.40 ●	02-8349104000
	Final Screw M1.6, Length 6 mm for ø 3.80 ●	02-8389104000
	Laboratory Screw M1.6, Length 6 mm	02-8169104000
	Final Screw M1.8, Length 6 mm for ø 4.10 ●	02-8419104000
	Final Screw M1.8, Length 6 mm for ø 5.00 ●	02-8509104000
	Laboratory Screw M1.8, Length 6 mm	02-8189104000
	Final Screw M1.4 for 4plus6Line	02-8149054000
	Laboratory Screw M1.4 for 4plus6Line	02-8149054100
	4plus6Line Scan Screw	02-8149064000
	M 1.4, Length 5,2 mm	

Note

M1.6
M1.8

The OT-F² implants ø 3.40/3.80 and OT-F³ implants ø 3.80 mm have inner threads of the size M1.6, the implants ø 4.10/ 5.00 mm size M1.8. Please remember this difference during use or reorder of the components.

Laboratory Screw
Final Screw

The Final Screws are color coded for differentiation. Please only use this Final Screw for the final fixation of the abutments in the patient's mouth.

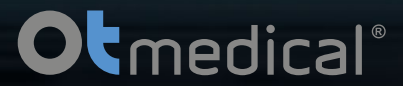

Innovative Präzision
Made in Germany

OT medical GmbH
Konsul-Smidt-Straße 8b
28217 Bremen, Germany
Tel. + 49 421 557161-0
Fax + 49 421 557161-95
info@ot-medical.de
www.ot-medical.de